



KGS-2420



Managed 24-Port Gigabit Ethernet Switch with 24 SFP Ports

Product Highlights:

- 24-Port Managed Gigabit switch
- 8 Combo RJ-45/SFP ports
- 16 Mini-GBIC SFP ports
- Web/Telnet/SNMP managed
- 802.1Q Tagged VLAN
- L2 to L4 QoS classification
- STP/RSTP/MSTP support
- Versatile network security support
- IGMP snooping
- RMON support
- Port data rate control

Combo Port x 8 (Port 1 ~ 8)



SFP Slot x 16 (Port 9 ~ 24)



KGS-2420, a 24-port Managed Gigabit Ethernet Switch, is a standard switch that meets all IEEE 802.3 Gigabit, Fast Ethernet specifications. The switch included 8 Combo, RJ-45/SFP ports and 16 Gigabit SFP fiber ports. The switch can be managed through RS-232 serial console port directly or through the switched ports using in-band CLI or Web-based interfaces, associated with SNMP agent. With the provided full management interfaces, the overall network management is enhanced and the network efficiency is also improved to accommodate high bandwidth applications. In addition, the switch also features comprehensive and useful functions such as QoS (Quality of Service), Spanning Tree, 802.1Q VLAN, Port Link Aggregation, Bandwidth Control, Port Security, SNMP/RMON, IGMP Snooping capability via the intelligent software. It is suitable for both metro-LAN and office application.

Key Features:

- Provides 8 auto-negotiation tri-speed Gigabit Combo ports with RJ-45 jack and SFP slot
- Provides 24 Mini-GBIC fiber ports to support up to 24 Gigabit fiber connections
- Provides non-blocking and wire speed forwarding and filtering
- Supports port-based and 802.1Q tag-based VLAN
- Supports Quality of Service (QoS) based on the information taken from Layer 2 to Layer 4
- Supports IEEE 802.1d, 802.1w, 802.1s STP (Spanning Tree Protocol), RSTP, MSTP
- Supports 802.1X port-based radius authentication for access security
- Supports IP Multicasting with IGMP Snooping function
- Supports configurable maximum frame length from 1518 up to 9KB jumbo frame
- Supports static and LACP port link aggregation
- Provides port mirroring function
- Provides SNMP event trap function
- Provides event system log function
- Provides port data rate control function
- Supports console and in-band Web/Telnet/SNMP interfaces for switch management
- Supports SNMP RMON
- Supports TFTP for firmware update and switch configuration file Upload/Download

Specifications:

Standard	IEEE 802.3, 802.3u, 802.3ab, 802.3z, 802.3x, 802.1Q, 802.1p
Network Ports	8 Gigabit Combo ports, 16 Gigabit SFP fiber ports
Combo Ports	Shielded RJ-45 connectors & Mini-GBIC SFP slot 10/100Mbps for full and half duplex, 1000Mbps for full duplex Auto-negotiation Auto-sense for copper and fiber link Auto-MDI/MDI-X crossover function for RJ-45
SFP Ports	Mini-GBIC ports for standard SFP fiber transceivers 1000Mbps for full duplex
Performance	48Gbps Non-blocking switching, Wire speed learning and forwarding



Network Cables	10/100Mbps copper: Cat.5 up to 100m 1000Mbps copper: Cat.5e or higher up to 100m Multimode fiber (MMF): 50/125µm, 62.5/125µm Single fiber (SMF): 9/125µm
MAC Address Table	8K entries
VLAN	4096 VLAN support, Port based VLAN, 8021Q Tag-based VLAN
QoS	2 priority queues Classification: Port-based, 802.1p, IP TOS, IP DSCP, L4 TCP/UDP
Bandwidth Control	Ingress rate control, Egress rate control
Link Aggregation	LACP or static trunking support Trunking groups: 12 max., Ports per group: 12
Network Security	802.1X port-based or MAC-based authentication for access control Access Control List IP-Mac binding for port access control
LED Indication	Per unit: Power, CPU Per copper port: Link/activity, Speed status Per SFP port: Link/activity status
Power Supply	100-240VAC, 50/60Hz, Consumption 40W
Dimension	442 x 209 x 44 mm (WxDxH)
Environment	Operating Temperature: 0°C ~ 40°C Storage Temperature: -20°C ~ 70°C Relative Humidity: 5% ~ 90% non-condensing
Approval	FCC Class A, CE mark Class A

Application:

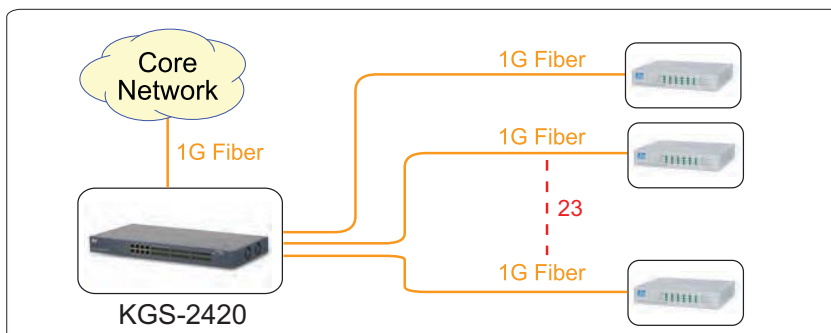
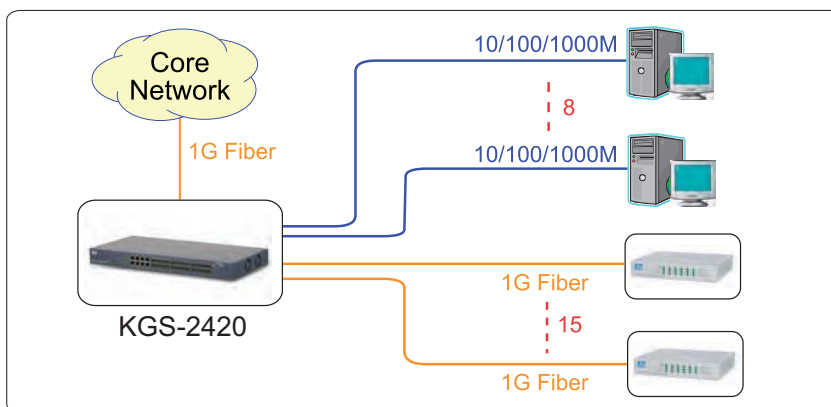

FCC Part 15, Class A
CISPR 22 Class A

Katron Technologies Inc.

15F-7, No. 79, Sec. 1, Hsin Tai Wu Rd.,
Hsi-chih, Taipei Hsien, Taiwan.
Tel: 886-2-2698-3878
Fax: 886-2-2698-3873
E-mail: kt@ktinet.com.tw
URL: http://www.ktinet.com.tw

KTI Networks Inc.

10415-A Westpark Drive, Houston,
TX 77042, U.S.A.
Tel: 1-713-266-3891
Fax: 1-713-914-0555
E-mail: contact@ktinet.com
URL: http://www.ktinet.com

Trademarks: All brand names are trademarks or registered trademarks of their respective holders.
This information is subject to change without prior notice.