

# KC-350

*PoE-PD-enabled 10/100Base-TX to  
100Base-FX Media Converters*

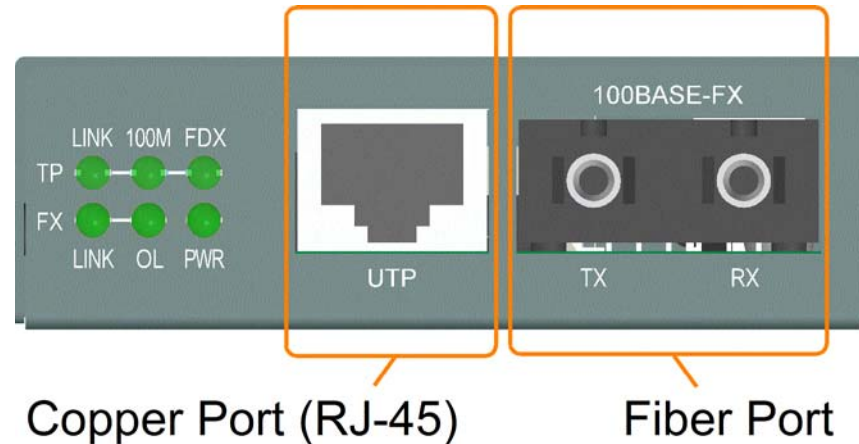

# Media Conversion



- 10Mbps, 100Mbps
- 10BASE-T
- 100BASE-TX
- Cat.5 or better
- 100Mbps
- 100BASE-FX
- Duplex MMF
- Duplex SMF
- Bi-Di single fiber
- CWDM

# Benefit 1: Direct Conversion

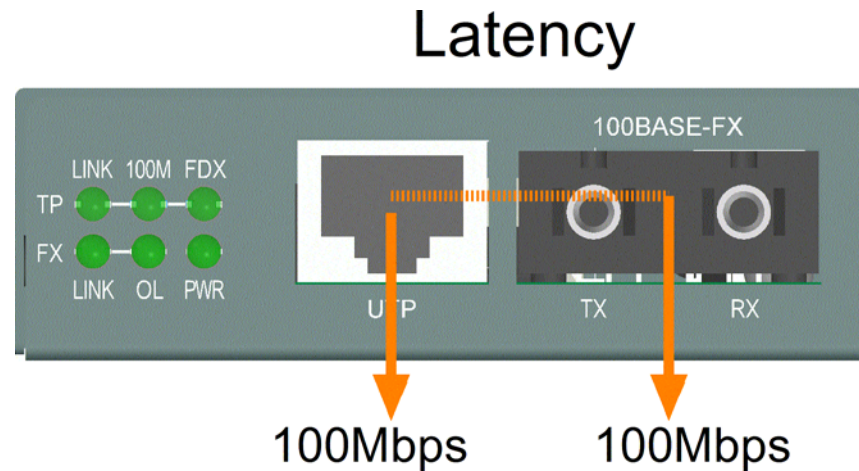

- No bridging conversion
- Direct conversion for 100M-to-100M conversion
- The least latency

# Benefit 2: Link Fault Pass Through

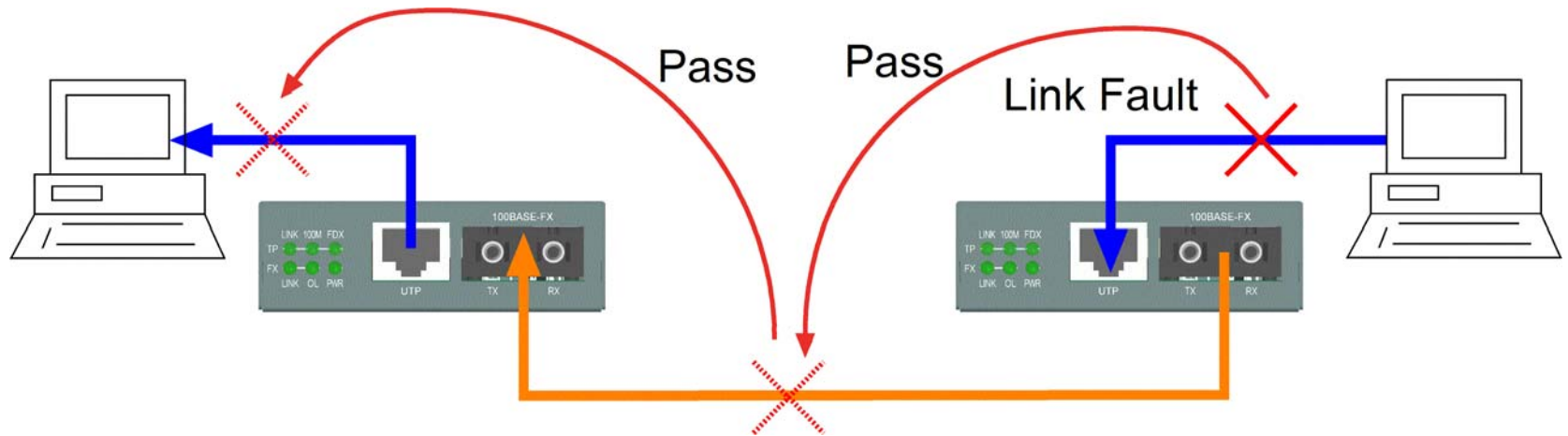

The device at local end is able to detect link fault at the remote copper connection.

# Benefit 3: Configuration Switches

## Configuration Switches

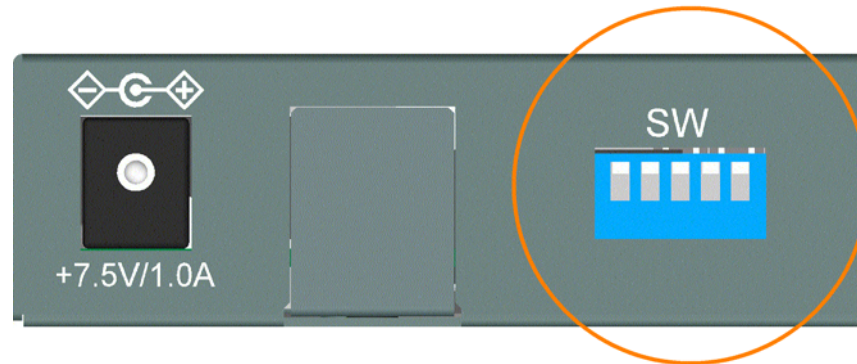

Allow to configure copper port to support connection to non-auto-negotiation devices.

# Benefit 4: Three Power Methods

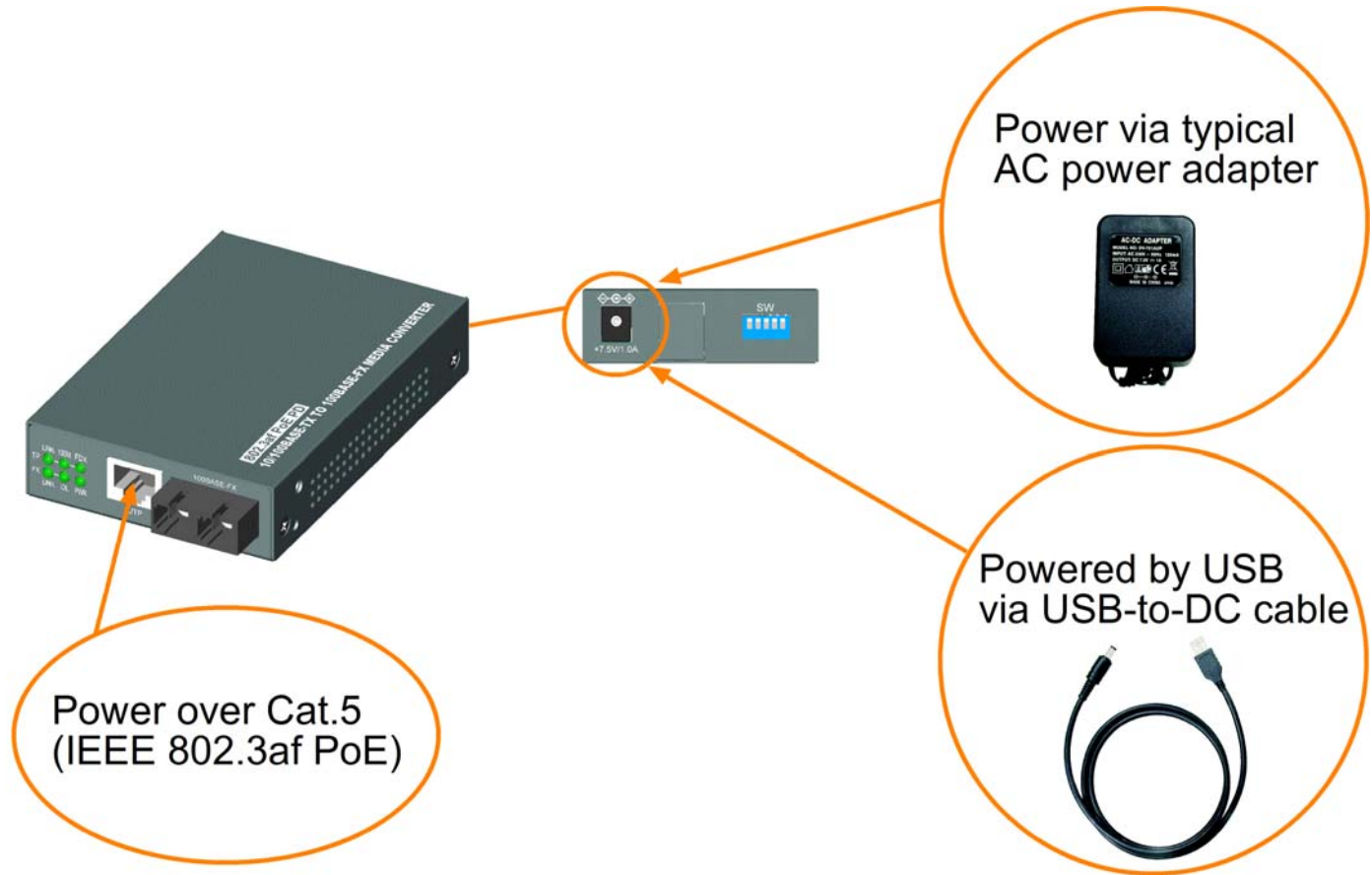



# Application 1: PoE Installation

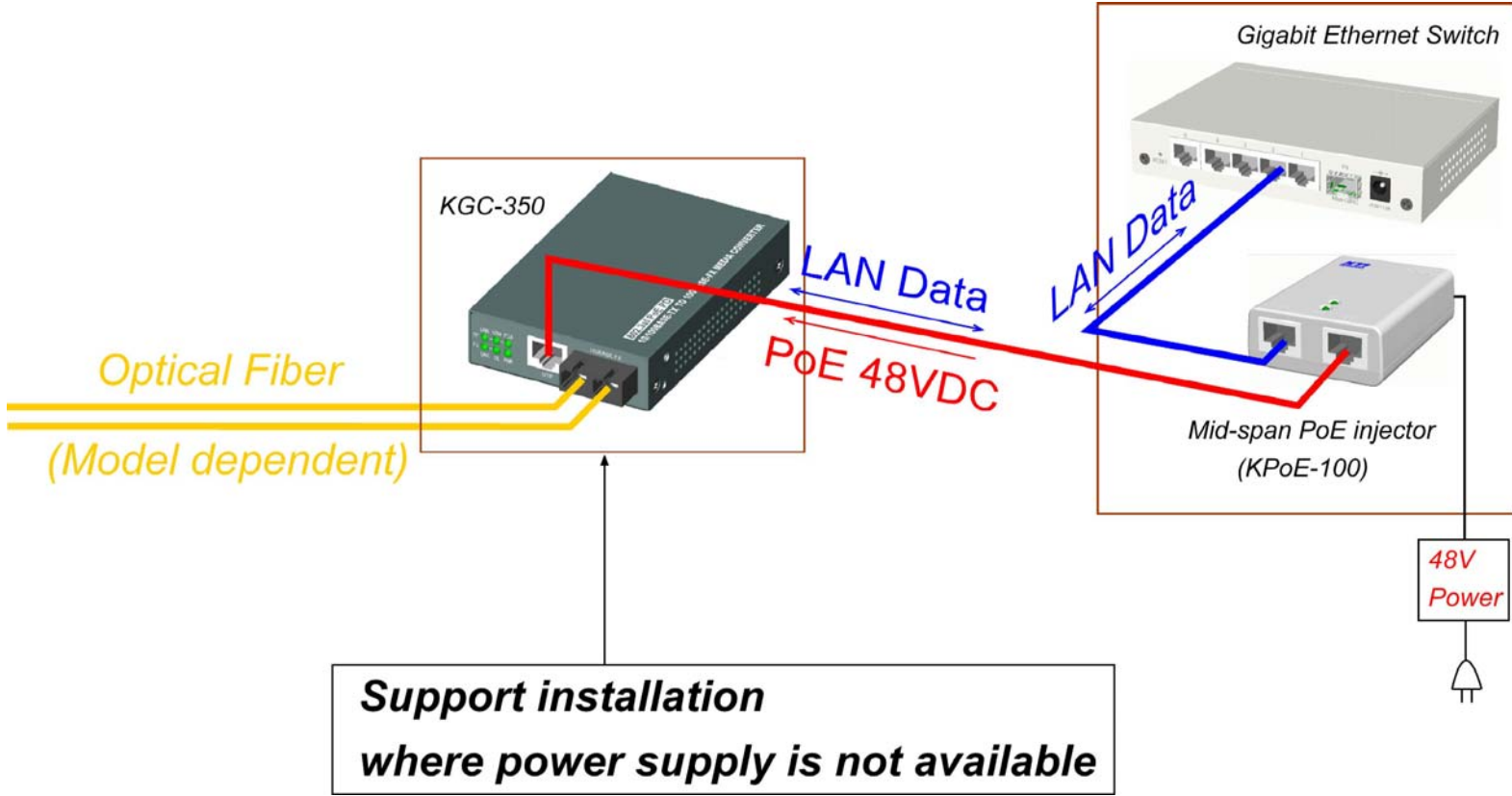

# Application 2: Long Reach SMF



# Application 3: Bi-Di Single Fiber

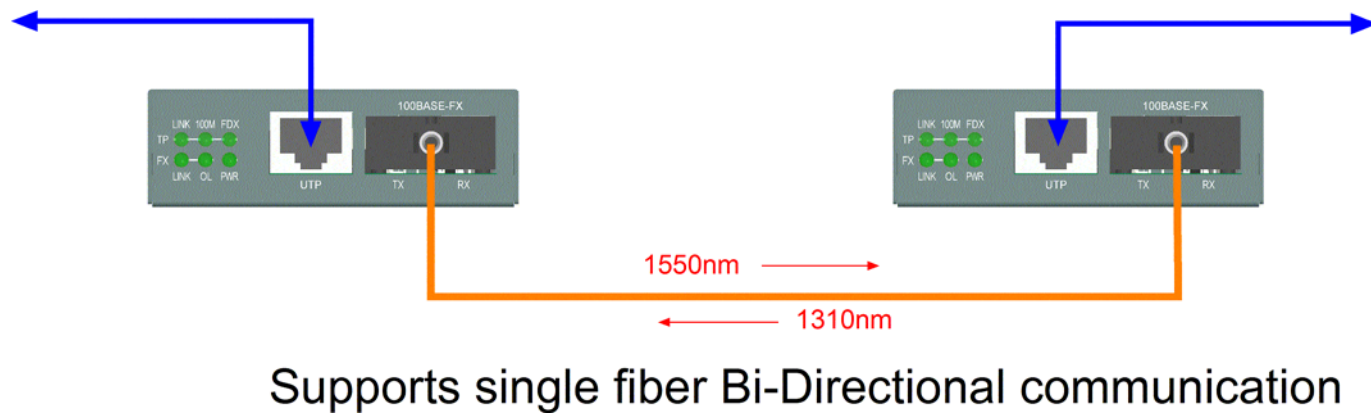

# Application 4: CWDM

